



Datalogic F725-E



User's Manual



Datalogic Mobile S.r.l.
Via S. Vitalino 13
40012 - Lippo di Calderara di Reno
Bologna - Italy

F725-E Series Terminals

Ed.: 06/2007



N2468

ALL RIGHTS RESERVED

Datalogic reserves the right to make modifications and improvements without prior notification.

Datalogic shall not be liable for technical or editorial errors or omissions contained herein, nor for incidental or consequential damages resulting from the use of this material.

Product names mentioned herein are for identification purposes only and may be trademarks and or registered trademarks of their respective companies.

© Datalogic S.p.A. 2001 - 2007

CONTENTS

	REFERENCES	iv
	Conventions	iv
	Reference Documentation	iv
	SERVICES AND SUPPORT	iv
	SAFETY REGULATIONS	v
	General Safety Rules	v
	Laser Safety	vi
	Radio Compliance	ix
	FCC Compliance	x
	WEEE Compliance	x
	GENERAL VIEW	xiii
1	INTRODUCTION	1
1.1	Terminal Description	1
1.1.1	F725-E	1
1.1.2	F725-E/RF	2
1.2	Application Development Programs	4
1.3	Downloading EasyGen™ Demo	5
1.4	Package Contents	5
1.5	Accessories	6
2	CONNECTIONS	7
2.1	Cradle	7
2.2	Connection to the Host Computer	8
2.2.1	RS232 Connection	8
2.2.2	Connection with Eavesdrop Interface	10
2.2.3	RS485 Connection	11
2.2.4	RF Connection	13
2.3	Connection Cable	14
3	USE AND OPERATION	16
3.1	Description of Keys Using EasyGen™	16
3.2	Barcode Scanning	19
3.3	Deleting the Application Program	20
3.4	Downloading Data to Host	21
4	MAINTENANCE	22
4.1	Charging the Batteries	22
4.2	Replacing the Batteries	24
4.3	Cleaning the Terminal	25
5	TROUBLESHOOTING	26
6	TECHNICAL FEATURES	27
	GLOSSARY	29
	INDEX	31

REFERENCES

CONVENTIONS

This manual uses the following conventions:

“User” or “Operator” refers to anyone using a F725-E Terminal.

“Device” refers to the F725-E Terminal.

“You” refers to the System Administrator or Technical Support person using this manual to install, operate, maintain or troubleshoot a F725-E Terminal.

REFERENCE DOCUMENTATION

For further details refer to the Manuals of the various programs provided when downloading the EasyGen™ Demo Version.

SERVICES AND SUPPORT

Datalogic provides several services as well as technical support through its website. Log on to www.datalogic.com and click on the [links](#) indicated for further information including:

- **PRODUCTS**

Search through the links to arrive at your product page where you can download specific **Manuals** and **Software & Utilities** including:

- **EasyGen™ Demo Version**
EasyGen™ Demo software allows developers to easily and quickly build personalized applications of average complexity in a Windows environment.
- **EasySend™**
A Windows-based file uploading program.

- **SERVICES & SUPPORT**

- **Datalogic Services** - Warranty Extensions and Maintenance Agreements
- **Authorised Repair Centres**

- **CONTACT US**

E-mail form and listing of Datalogic Subsidiaries

SAFETY REGULATIONS



NOTE

Read this manual carefully before performing any type of connection or repair on the terminal.

The user is responsible for any damages caused by incorrect use of the equipment or by inobservance of the indication supplied in this manual.

GENERAL SAFETY RULES

Use only the components supplied by the manufacturer for the specific F725-E series terminal being used. The use of cradles other than those supplied with the terminal or indicated in the list in the appendix could cause serious damage to the terminal.

Do not attempt to disassemble the F725-E series terminal, as it does not contain parts that can be repaired by the user. Any tampering will invalidate the warranty.

When replacing the batteries or at the end of the operative life of the terminal, disposal must be performed in compliance with the laws in force.

Do not submerge the terminal in liquid products.

LASER SAFETY

The laser light is visible to the human eye and is emitted from the window indicated in the figure.

F725-E

Laser beam output window



Figure 1 - F725-E Laser Safety Labels

F725-E/RF

Laser beam output window



Figure 2 - F725-E/RF Laser Safety Labels

I	D	F	E
LA LUCE LASER È VISIBILE ALL'OCCHIO UMANO E VIENE EMESSA DALLA FINESTRA INDICATA NELLA FIGURA.	DIE LASER-STRABLUNG IST FÜR DAS MENSCHLICHE AUGE SICHTBAR UND WIRD AM STRAHLAUS-TRITTSFENSTER AUSGESENDET (SIEHE BILD)	LE RAYON LASER EST VISIBLE À L'OEIL NU ET IL EST ÉMIS PAR LA FENÊTRE DÉSIGNÉE SUR L'ILLUSTRATION DANS LA FIGURE	A LUZ LÁSER ES VISIBILE AL OJO HUMANO Y ES EMITIDA POR LA VENTANA INDICADA EN LA FIGURA.
LUCE LASER NON FISSARE IL FASCIO APPARECCHIO LASER DI CLASSE 2 MASSIMA POTENZA D'USCITA: LUNGHEZZA D'ONDA EMESSA: CONFORME A EN 60825-1(2001)	LASERSTRABLUNG NICHT IN DEN STRAHL BLICKEN PRODUKT DER LASERKLASSE 2 MAXIMALE AUSGANGSLEISTUNG: WELLENLÄGE: ENTSPR. EN 60825-1(2001)	RAYON LASER EVITER DE REGARDER LE RAYON APPAREIL LASER DE CLASSE 2 PUISSANCE DE SORTIE: LONGUER D'ONDE EMISE: CONFORME A EN 60825-1 (2001)	RAYO LÁSER NO MIRAR FIJO EL RAYO APARATO LÁSER DE CLASE 2 MÁXIMA POTENCIA DE SALIDA: LONGITUD DE ONDA EMITIDA: CONFORME A EN 60825-1 (2001)

ENGLISH

The following information is provided to comply with the rules imposed by international authorities and refers to the correct use of your terminal.

STANDARD LASER SAFETY REGULATIONS

This product conforms to the applicable requirements of both CDRH 21 CFR 1040 and EN 60825-1 at the date of manufacture.

For installation, use and maintenance, it is not necessary to open the device.



CAUTION

Use of controls or adjustments or performance of procedures other than those specified herein may result in exposure to hazardous visible laser light.

The product utilizes a low-power laser diode. Although staring directly at the laser beam momentarily causes no known biological damage, avoid staring at the beam as one would with any very strong light source, such as the sun. Avoid that the laser beam hits the eye of an observer, even through reflective surfaces such as mirrors, etc.

ITALIANO

Le seguenti informazioni vengono fornite dietro direttive delle autorità internazionali e si riferiscono all'uso corretto del terminale.

NORMATIVE STANDARD PER LA SICUREZZA LASER

Questo prodotto risulta conforme alle normative vigenti sulla sicurezza laser alla data di produzione: CDRH 21 CFR 1040 e EN 60825-1.

Non si rende mai necessario aprire l'apparato per motivi di installazione, utilizzo o manutenzione.



ATTENZIONE

L'utilizzo di procedure o regolazioni differenti da quelle descritte nella documentazione può provocare un'esposizione pericolosa a luce laser visibile.

Il prodotto utilizza un diodo laser a bassa potenza. Sebbene non siano noti danni riportati dall'occhio umano in seguito ad una esposizione di breve durata, evitare di fissare il raggio laser così come si eviterebbe qualsiasi altra sorgente di luminosità intensa, ad esempio il sole. Evitare inoltre di dirigere il raggio laser negli occhi di un osservatore, anche attraverso superfici riflettenti come gli specchi.

DEUTSCH

Die folgenden Informationen stimmen mit den Sicherheitshinweisen überein, die von internationalen Behörden auferlegt wurden, und sie beziehen sich auf den korrekten Gebrauch vom Terminal.

NORM FÜR DIE LASERSICHERHEIT

Dies Produkt entspricht am Tag der Herstellung den gültigen EN 60825-1 und CDRH 21 CFR 1040 Normen für die Lasersicherheit.

Es ist nicht notwendig, das Gerät wegen Betrieb oder Installations-, und Wartungsarbeiten zu öffnen.



ACHTUNG

Jegliche Änderungen am Gerät sowie Vorgehensweisen, die nicht in dieser Betriebsanleitung beschreiben werden, können ein gefährliches Laserlicht verursachen.

Das Produkt benutzt eine Laserdiode. Obwohl zur Zeit keine Augenschäden von kurzen Einstrahlungen bekannt sind, sollten Sie es vermeiden für längere Zeit in den Laserstrahl zu schauen, genauso wenig wie in starke Lichtquellen (z.B. die Sonne). Vermeiden Sie es, den Laserstrahl weder gegen die Augen eines Beobachters, noch gegen reflektierende Oberflächen zu richten.

FRANÇAIS

Les informations suivantes sont fournies selon les règles fixées par les autorités internationales et se réfèrent à une correcte utilisation du terminal.

NORMES DE SECURITE LASER

Ce produit est conforme aux normes de sécurité laser en vigueur à sa date de fabrication: CDRH 21 CFR 1040 et EN 60825-1.

Il n'est pas nécessaire d'ouvrir l'appareil pour l'installation, l'utilisation ou l'entretien.



ATTENTION

L'utilisation de procédures ou réglages différents de ceux donnés ici peut entraîner une dangereuse exposition à lumière laser visible.

Le produit utilise une diode laser. Aucun dommage aux yeux humains n'a été constaté à la suite d'une exposition au rayon laser. Eviter de regarder fixement le rayon, comme toute autre source lumineuse intense telle que le soleil. Eviter aussi de diriger le rayon vers les yeux d'un observateur, même à travers des surfaces réfléchissantes (miroirs, par exemple).

ESPAÑOL

Las informaciones siguientes son presentadas en conformidad con las disposiciones de las autoridades internacionales y se refieren al uso correcto del terminal.

NORMATIVAS ESTÁNDAR PARA LA SEGURIDAD LÁSER

Este aparato resulta conforme a las normativas vigentes de seguridad láser a la fecha de producción: CDRH 21 CFR 1040 y EN 60825-1.

No es necesario abrir el aparato para la instalación, la utilización o la manutención.



ATENCIÓN

La utilización de procedimientos o regulaciones diferentes de aquellas descritas en la documentación puede causar una exposición peligrosa a la luz láser visible.

El aparato utiliza un diodo láser a baja potencia. No son notorios daños a los ojos humanos a consecuencia de una exposición de corta duración. Eviten de mirar fijo el rayo láser así como evitarían cualquiera otra fuente de luminosidad intensa, por ejemplo el sol. Además, eviten de dirigir el rayo láser hacia los ojos de un observador, también a través de superficies reflectantes como los espejos.

RADIO COMPLIANCE

Information for the User

ENGLISH

Contact the competent authority responsible for the management of radio frequency devices of your country to verify the eventual necessity of a user license. Refer to the web site <http://europa.eu.int/comm/enterprise/rte/spectr.htm> for further information.

ITALIANO

Prendi contatto con l'autorità competente per la gestione degli apparati a radio frequenza del tuo paese, per verificarne l'eventuale necessità della licenza d'uso. Inoltre puoi trovare ulteriori informazioni al sito:

<http://europa.eu.int/comm/enterprise/rtte/spectr.htm>.

FRANÇAIS

Contactez l'autorité compétente en la gestion des appareils à radio fréquence de votre pays pour vérifier la nécessité du permis d'usage. Pour tout renseignement vous pouvez vous adresser au site web:

<http://europa.eu.int/comm/enterprise/rtte/spectr.htm>.

DEUTSCH

Um die Notwendigkeit der Verwendungslizenz zu prüfen, wenden Sie sich an die Behörde, die auf der Radiofrequenzgerätsführung Ihres Lands bewandert ist. Weitere Informationen sind verfügbar auf dem Web Site:

<http://europa.eu.int/comm/enterprise/rtte/spectr.htm>.

ESPAÑOL

Contacta con la autoridad competente para la gestión de los dispositivos de radio frecuencia de tu país, para verificar si es necesario la licencia de uso. Además se puede encontrar mas información en el sitio web:

<http://europa.eu.int/comm/enterprise/rtte/spectr.htm>.



FCC COMPLIANCE

This compliance refers only to the F725-E batch models.

Modifications or changes to this equipment without the expressed written approval of Datalogic could void the authority to use this equipment.

This device complies with PART 15 of the FCC Rules. Operation is subject to the following two conditions: (1) This device may not cause harmful interference, and (2) this device must accept any interference which may cause undesired operation.

This equipment has been tested and found to comply with the limits for a Class A digital device, pursuant to part 15 of the FCC Rules. These limits are designed to provide reasonable protection against harmful interference when the equipment is operated in a commercial environment. This equipment generates, uses, and can radiate radio frequency energy and, if not installed and used in accordance with the instruction manual, may cause harmful interference to radio communications. Operation of this equipment in a residential area is likely to cause harmful interference in which case the user will be required to correct the interference at his own expense.

WEEE COMPLIANCE



Informazione degli utenti ai sensi della Direttiva Europea 2002/96/EC

L'apparecchiatura che riporta il simbolo del bidone barrato deve essere smaltita, alla fine della sua vita utile, separatamente dai rifiuti urbani.

Smaltire l'apparecchiatura in conformità alla presente Direttiva consente di:

- evitare possibili conseguenze negative per l'ambiente e per la salute umana che potrebbero invece essere causati dall'errato smaltimento dello stesso;
- recuperare materiali di cui è composto al fine di ottenere un importante risparmio di energia e di risorse.

Per maggiori dettagli sulle modalità di smaltimento, contattare il Fornitore dal quale è stata acquistata l'apparecchiatura o consultare la sezione dedicata sul sito www.mobile.datalogic.com.

Information for the user in accordance with the European Commission Directive 2002/96/EC

At the end of its useful life, the product marked with the crossed out wheeled wastebin must be disposed of separately from urban waste.

Disposing of the product according to this Directive:

- avoids potentially negative consequences to the environment and human health which otherwise could be caused by incorrect disposal
- enables the recovery of materials to obtain a significant savings of energy and resources.

For more detailed information about disposal, contact the supplier that provided you with the product in question or consult the dedicated section at the website www.mobile.datalogic.com.

Information aux utilisateurs concernant la Directive Européenne 2002/96/EC

Au terme de sa vie utile, le produit qui porte le symbole d'un caisson à ordures barré ne doit pas être éliminé avec les déchets urbains.

Éliminer ce produit selon cette Directive permet de:

- éviter les retombées négatives pour l'environnement et la santé dérivant d'une élimination incorrecte
- récupérer les matériaux dans le but d'une économie importante en termes d'énergie et de ressources

Pour obtenir des informations complémentaires concernant l'élimination, veuillez contacter le fournisseur auprès duquel vous avez acheté le produit ou consulter la section consacrée au site Web www.mobile.datalogic.com.

Información para el usuario de acuerdo con la Directiva Europea 2002/96/CE

Al final de su vida útil, el producto marcado con un símbolo de contenedor de basura móvil tachado no debe eliminarse junto a los desechos urbanos.

Eliminar este producto de acuerdo con la Directiva permite de:

- evitar posibles consecuencias negativas para el medio ambiente y la salud derivadas de una eliminación inadecuada
- recuperar los materiales obteniendo así un ahorro importante de energía y recursos

Para obtener una información más detallada sobre la eliminación, por favor, póngase en contacto con el proveedor donde lo compró o consultar la sección dedicada en el Web site www.mobile.datalogic.com.

Benutzerinformation bezüglich Richtlinie 2002/96/EC der europäischen Kommission

Am Ende des Gerätelebenszyklus darf das Produkt nicht über den städtischen Hausmüll entsorgt werden. Eine entsprechende Mülltrennung ist erforderlich.

Beseitigung des Produkts entsprechend der Richtlinie:

- verhindert negative Auswirkungen für die Umwelt und die Gesundheit der Menschen
- ermöglicht die Wiederverwendung der Materialien und spart somit Energie und Ressourcen

Weitere Informationen zu dieser Richtlinie erhalten sie von ihrem Lieferanten über den sie das Produkt erworben haben, oder besuchen sie unsere Homepage unter www.mobile.datalogic.com.

GENERAL VIEW

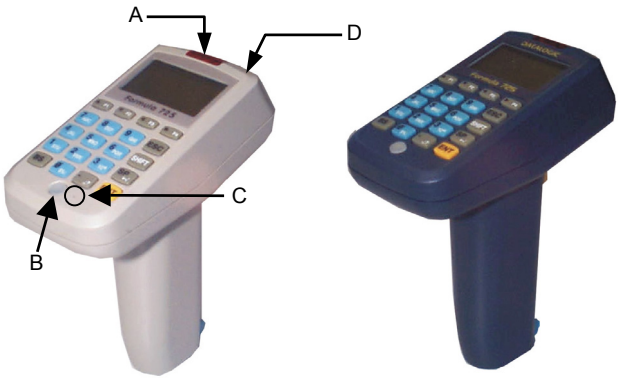

Figure 3 - F725-E Series Terminals Overview

Key:

- A) Cradle communications window
- B) Multi-function LED
- C) Reset key (protected)
- D) Laser beam output window

1 INTRODUCTION

1.1 TERMINAL DESCRIPTION

Two different models of this terminal are provided:

- Formula 725-E:** communicates with the host computer via a cradle connection;
- Formula 725-E/RF:** communicates with the host computer via radio frequency or normal cradle connection.

1.1.1 F725-E

The F725-E Hand-Held Laser Terminal offers features and functionality typical of high-end product. Compact and lightweight, with up to 2 MB of RAM memory for managing large databases and 512 KB of Flash memory for application programs of large dimensions, F725-E solves the most complex application needs.

Furthermore, the "overspeed" capability boosts software performance, thus increasing the operator's productivity.

The F725-E Long Range model enables reading of barcodes located in difficult-to-reach places even up to 1.5m away, while the reading capability of the standard model is the best you can desire due to the high performance and high visibility laser engine allowing barcodes to be scanned up to a distance of 70 cm.

The long life batteries assure large autonomy being able to cover more than one work shift. The wide backlit LCD display with 4 lines and 16 characters clearly shows much information, while the practical 20-key alphanumeric keyboard allows data, codes and descriptions to be input very quickly.

Protection against bumps, dust and water are all features that make F725-E suitable for intensive use even in industrial environments.

By using the optional EasyGen™ Application Generator or DS for Formula™ software packages for Windows environment, developers can easily customize applications according to the end user specific needs. Most of the applications in the Distribution & Retail market can take advantage of the distinctive F725-E/RF features, especially in warehousing/back office environments. Nevertheless, the F725-E/RF can solve many applications even in Transportation & Logistics and Manufacturing markets thanks to the best price/performance ratio of its category.

1.1.2 F725-E/RF

The F725-E/RF terminal is a lightweight, compact-sized and fully programmable radio frequency terminal 100% compatible with the Datalogic STAR-System™, the RF narrow band solution for mobile applications. It solves the most complex application needs, exploits the "overspeed" feature to boost software performance, and has 512 KB of RAM memory for managing large databases and 512 KB of Flash memory for application programs of large dimensions.

The reading capability of the standard model is the best you can desire due to the high performance and high visibility laser engine allowing barcodes to be scanned up to a distance of 70 cm. The F725-E/RF Long Range model enables reading of barcodes located in difficult-to-reach places even up to 1.5 m away.

Furthermore, the long life batteries assure large autonomy being able to cover more than one work shift, while protection against bumps, dust and water are all features that make F725-E/RF suitable for intensive use even in industrial environments.

Software developers can easily customize applications according to the specific needs of the end user by using the DS for Formula™ software package and integrating F725-E/RF within the new Datalogic STAR-System™.

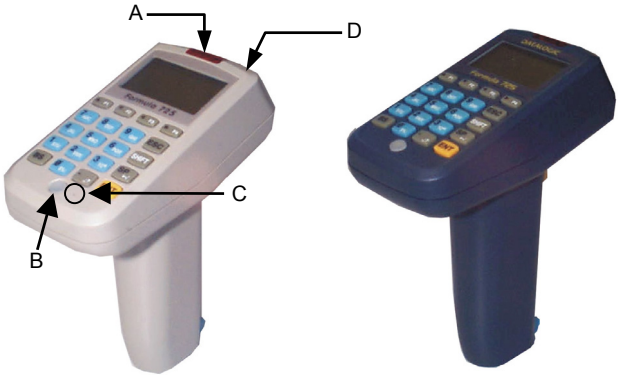

Figure 4 - F725-E Series Terminals Overview

Key:

- A) Cradle communications window
- B) Multi-function LED
- C) Reset key (protected)
- D) Laser beam output window

The F725-E series terminals have a backlit LCD graphic display of 16 characters by 4 lines plus a line in the upper part of the display for the programmable icons:

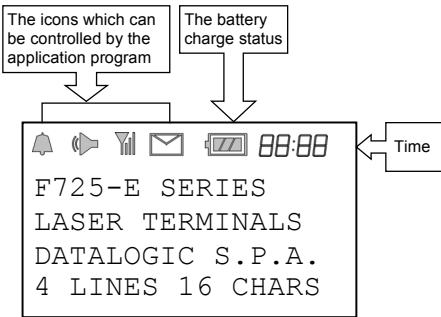

Figure 5 - Terminal Display

1.2 APPLICATION DEVELOPMENT PROGRAMS

By using the optional **EasyGen™** Application Generator or the DS for Formula™ software package, developers can easily customize applications according to the end user specific needs, solving the most common data collection applications such as inventory, picking and shipping/receiving.

EasyGen™ is the ideal solution for making **Formula 725-E batch terminals** productive instantly. In a familiar environment, developers have all the instruments at their disposal to reduce programming times (and therefore costs) while maintaining a high standard of quality in the creation of personalized applications whatever their nature, whether simple (e.g. a program for inserting codes/quantities) or more sophisticated.

The EasyGen™ package includes Systools™ 2001, the efficient software utility to transfer data to standard ASCII files, and OLE for Formula, the software module ActiveX - OLE Custom Control or OCX - allowing users to easily integrate their data into applications such as Visual Basic, Excel, Access, Delphi, etc.

DS for Formula™ is a software package that provides instruments for fully exploiting **F725-E** and **F725-E/RF** terminals by creating fully-structured and personalized applications (see par. 1.2 for details).

DS for Formula™ uses a «C» standard ANSI compiler, integrated with special libraries, operating in an MS-DOS environment and developed specifically for the type of terminal processor. The libraries, developed by Datalogic, permit direct management of the terminal functions. For example, the management of barcode reading devices is immediate and rational thanks to interaction with functions that automatically start up the barcode acquisition procedure.

Equally transparent, by using a philosophy of events programming, is the procedure managing the keyboard, display, serial and radio-frequency communication, calendar/clock and, either directly or through a vdisk function, the data memory organized into banks.

DS for Formula™ also offers a series of effective general purpose application examples which represent an excellent starting point while simultaneously providing a practical guide for studying and working on complex or personalized programs. Refer to the "Tools" paragraph in the DS for Formula™ Manual for details.

1.3 DOWNLOADING EASYGEN™ DEMO

By logging on to www.datalogic.com/services/support and clicking on the [Products>Portable Data Collection Terminals](#) link, you can download for free the EasyGen™ Demo Software package containing the following items:

- EasyGen™ Demo Version (user-friendly and highly productive application generator)
- SysTools™2001 (efficient utility for data exchange with the terminal)
- OLE for Formula (useful ActiveX software module for easy integration of Windows applications)
- The most common application examples (data collection, inventory, goods picking, assisted sales) available in 5 languages (English, French, German, Italian, Spanish)
- The complete documentation in PDF format.

1.4 PACKAGE CONTENTS

The F725-E terminal package includes:

- n. 1 F725-E terminal complete with batteries;
- n. 1 user's manual
- n. 1 test chart

The F725-E/RF terminal package includes:

- n. 1 F725-E/RF terminal complete with batteries;
- n. 1 user's manual
- n. 1 test chart



CAUTION

Remove all components from their packing and check that they are in good condition and that they correspond to the shipment documents.

Keep the packing and boxes in case it is necessary to send the terminal back for technical assistance. Damage caused by improper packing is not covered by the warranty



NOTE

Rechargeable battery packs are not initially charged.

Therefore the first operation to perform is to charge them in the appropriate cradle (see par. 2.2.1 and par. 4.1).

1.5 ACCESSORIES

- F925 – F925 Dark**
Transceiver/Charger - RS232/RS485
- F925/4**
Transceiver/Charger - 4 slots - RS232(x1)/RS485(x4)
- F902**
T-Box
- NCK**
RS485 Network/PC connection kit
- Functional Case** – order number 94ACC1267

- FBK725-E**
Battery kit NiMh 725-E
- FBS725-E**
Battery kit NiMh F725-E (5 pcs pack)
- FCB232 D 25 F**
RS232 serial connection cable for PC/XT T 8 M - D25 F 2 m
- FCB232 D 9 F**
RS232 serial connection cable for PC/AT T 8 M - D9 F 2 m
- FCB485 SYS**
RS485 serial connection cable for SYSNET 2 m
- FCB EAV**
Eavesdrop cable kit 2+2 m
- DS for Formula™**
Development system for Formula Basic Line
- CA51**
Compiler 8051 Compiler kit V7 for F6XX and F7XX
- EasyGen™**
Easy application generator package for Formula batch terminals: F660-E, F725-E, F732-E, F734-E
- Utility Tools Full Pack Adv. Ed. F725**
Software package for Windows 95, 98, NT
- ForWin™**
Software package for developing RF terminal applications
- STARGATE™**
Radio base station allowing data transmission in wireless network
- STAR★Modem™**
Radio modem providing wireless RF communication
- STAR-Box™**
Connection box

2 CONNECTIONS

2.1 CRADLE

To make the F725-E series terminal operative, it is necessary to insert it into the Formula 925 Transceiver Charger cradle or into the Formula 925/4 Multi Transceiver Charger which has been previously connected to the power supply and to a host computer with an available RS232, RS485 or Eavesdrop line.

The following figure describes the F925 cradle:

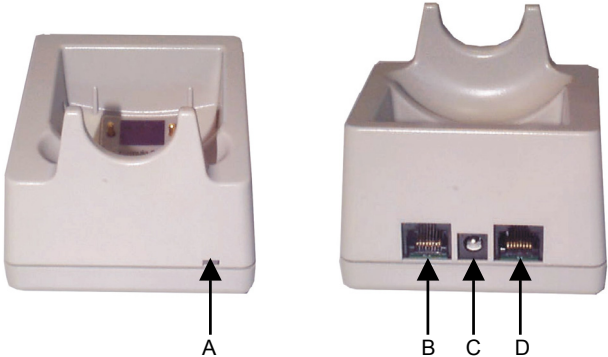



Figure 6 - F925 Cradle Overview

Key:

- A) Red/Green LED:
Green = terminal not inserted or charge level being maintained
Red = charge in progress
- B) RJ connector for RS485 and Eavesdrop connection
- C) Power jack (9 V)
- D) RJ connector for RS232 and RS485 host connection



The use of cradles other than those expressly specified may damage the terminal.

CAUTION

2.2 CONNECTION TO THE HOST COMPUTER



CAUTION

Before proceeding with this phase, make sure that both the computer and the terminal are switched off.

2.2.1 RS232 Connection

To connect the F925 cradle to the host computer, proceed as indicated below:

- 1- Connect the cable to the serial port of the host computer.
- 2- Connect the other end of the same cable (RJ connector) to the RS232 port of the cradle (point D in the previous figure).
- 3- Insert the power-supply plug into the jack on the base of the cradle (point C in the previous figure).
- 4- Attach the power supply to a power outlet.
- 5- Turn on the computer.
- 6- Put the F725-E batch terminal into the cradle and, if necessary, recharge the batteries.

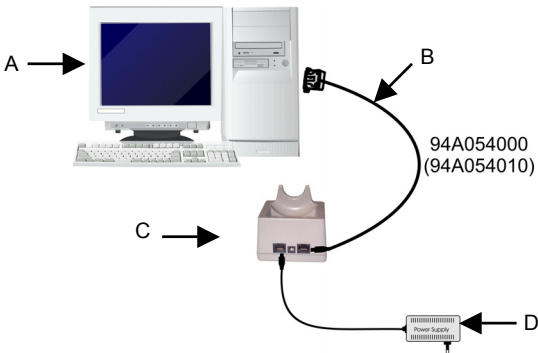

Figure 7 - RS232 Single Cradle Connection

Key:

- A) Host computer
- B) Serial cable
- C) Single cradle F925
- D) Power supply

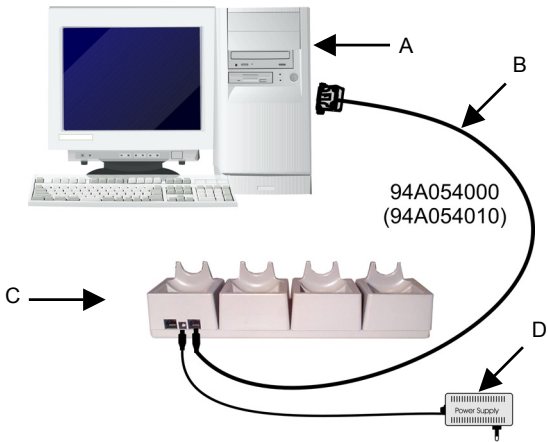

Figure 8 - RS232 Multi Cradle Connection

Key:

- A) Host computer
- B) Serial cable
- C) Multi-cradle F925/4
- D) Power supply



NOTE

The RS232 connection allows transmission between the host computer and the first station of the multi-cradle. For this reason, it is necessary to insert an RS232/RS485 converter between the host and the cradle to enable transmission with all the four stations.

2.2.2 Connection with Eavesdrop Interface

The cable Kit 94A054030 provides two cables; one for Eavesdrop connections and one for Modem connections.

The Eavesdrop connection enables the F725-E terminal to be connected to an existing asynchronous RS232 line (for example between the host computer and video terminal).

The modem connection enables the terminal to be connected to a host system using a modem.

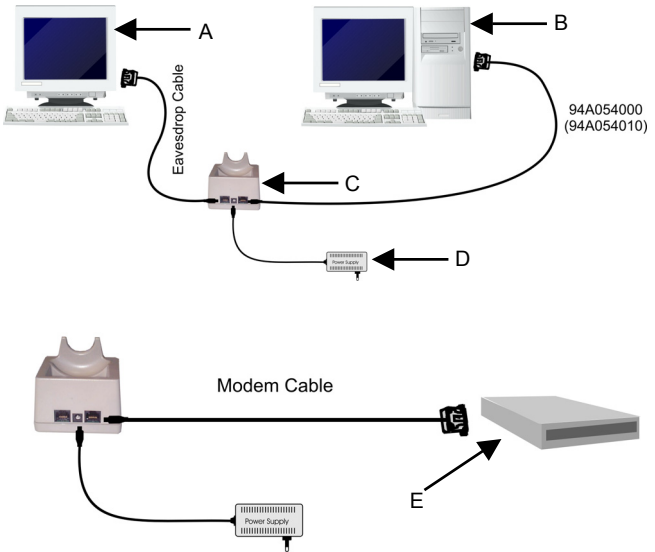

Figure 9 - Eavesdrop and Modem Connection

Key:

- A) Video terminal
- B) Host computer
- C) Cradle F925
- D) Power supply
- E) Modem

2.2.3 RS485 Connection

The RS485 line allows connecting several terminals to a single RS232 line by means of a network (see the "Formula 904/N User Manual").

If the network is made using the Formula 902 T-Box, the line can be extended up to 1200 meters and up to 32 different types of Formula cradles can be connected. If multiple cradles are used, the individual work stations must be counted.

**NOTE**

The RS485 connection is the only one allowing all the stations of a multi-cradle to be available for transmission/reception from the host computer.

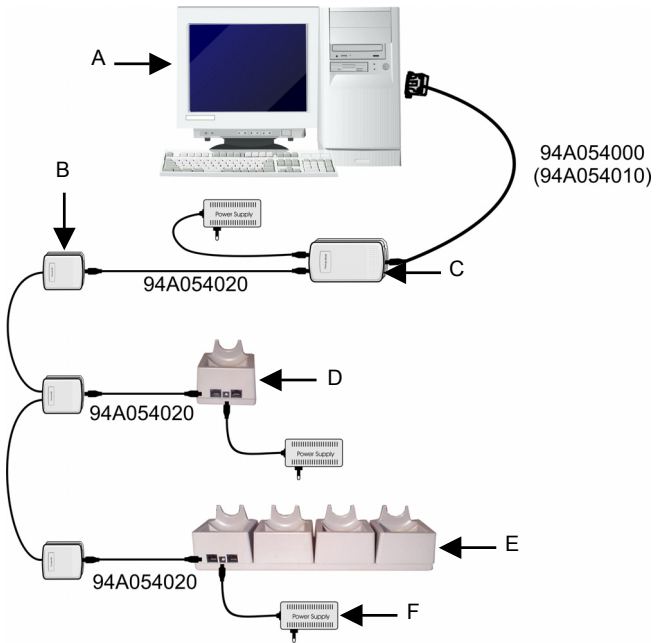

Figure 10 - RS485 Connection

Key:

- A) Host computer
- B) Formula 902 T-box
- C) Formula 904/N Interconverter
- D) Single cradle F925
- E) Multi cradle F925/4
- F) Power supply

2.2.4 RF Connection

The RF connection allows the F725-E/RF terminal to communicate with the host via radio frequency using the STARGATE™ RF base station connected to the host computer.

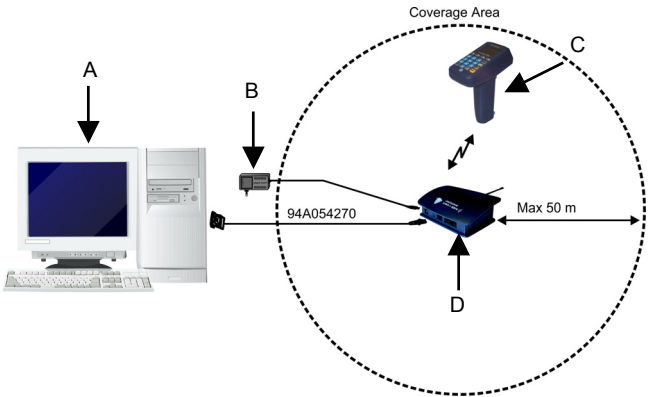

Figure 11 - RF Connection

Key:

- A) Host computer
- B) Power supply
- C) Formula 725-E/RF
- D) STARGATE™ RF base station

2.3 CONNECTION CABLE

Several types of cables are provided depending on the computer and on the connection. The following cables and cable Kits are listed with their order number.

- RS232 Connection with PC/AT or compatible: cable 94A054000**

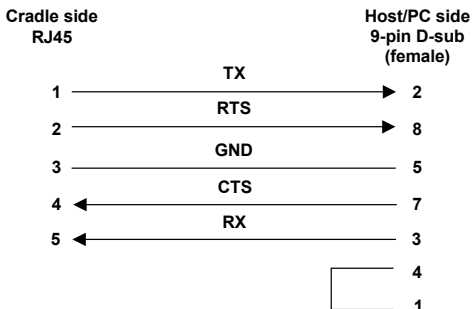

- Modem and/or Eavesdrop Connection: cable Kit 94A054030**

The **beige** cables allowing the Eavesdrop connection have the following pinout:

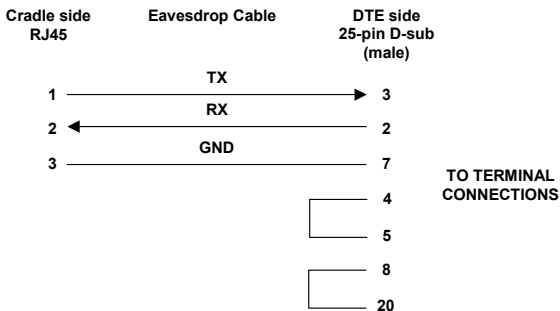

The **black flat** cable allowing the Modem connection has the following pinout:

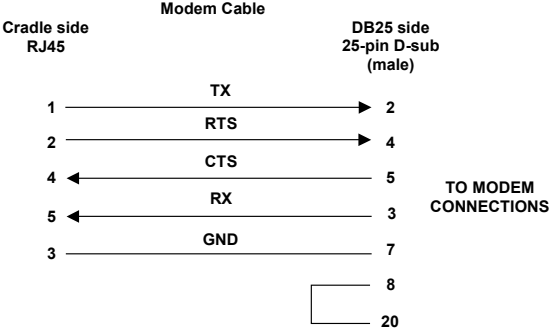

□ RS485 Connection: cable 94A054020

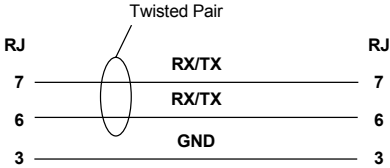

3 USE AND OPERATION

The F725-E and F725-E/RF are lightweight, pocket-sized and fully programmable terminals with 512 KB of RAM memory to manage large databases and 512 KB of Flash memory for application programs of large dimensions.



NOTE

It is necessary to load an application program onto the terminal to exploit its features.

By using the optional EasyGen™ Application Generator or the DS for Formula™ software package, developers can easily customize applications according to the end user specific needs, solving the most common data collection applications such as inventory, picking and shipping/receiving

The Demo Version of EasyGen™ can be downloaded free of charge from the Datalogic web site together with 5 ready-to-use example applications in 5 different languages. Refer to chapter 6 of the EasyGen™ User's Manual for details.

The following descriptions assume the terminal is loaded with an EasyGen™ application. If however, a custom application is loaded then refer to the specific documentation for terminal operation.

3.1 DESCRIPTION OF KEYS USING EASYGEN™

It is possible to assign customized functions to function keys depending on the application program developed. The functions described below refer to a terminal loading an application program developed with the EasyGen™ Application Generator.



ATTENTION

Refer to chapter 6 "EasyGen™ Interpreter Program" of the EasyGen™ User's Manual for more details about the key functions.



NOTE

To select the white characters on the keyboard press <SHIFT> followed by the required key.



ARROW KEYS: activate display scroll in the direction indicated by the arrow when the function is assigned by the application program. Function F% activates the "Select" mode and only in this mode you can use F6, F7 and F8 functions:

<SHIFT><SHIFT><Up Arrow> = F5 "Select" mode
 <SHIFT><SHIFT><Down Arrow> = F6 Data search
 <SHIFT><SHIFT><Left Arrow> = F7 Deletion
 <SHIFT><SHIFT><Right Arrow> = F8 Data display

FUNCTION KEYS: activate the function assigned by the application program.



ESC KEY: quit a previously enabled function.



SHIFT KEY: Enables the entry of alphabetical characters (written in white on the keyboard) when followed by the pressing of a numeric key: for example if you want to enter the alphabetical character "A", you have to press <SHIFT>+<7>.

The number of times the numeric key is pressed determines the choice of alphabetical character: for example if you want to enter the alphabetical character "N", you have to press <SHIFT>+<5>+<5>, if you want to enter the alphabetical character "X", you have to press

<SHIFT>+<2>+<2>+<2> and so on.

The fourth time an alphanumeric key is pressed, the SHIFT function is disabled. The SHIFT function can also be disabled by waiting for a time-out of 2 seconds after an alphanumeric key is first pressed.



NUMERIC AND ALPHANUMERIC KEYS: allow the entry and display of the main numeric symbol. If the <SHIFT> has first been pressed, the choice of alternative alphabetic characters will be activated.



BACKSPACE KEY: deletes the last character entered.



SPACE KEY: allows the introduction of a blank space. If the <SHIFT> has been pressed previously, the choice of alternative characters will be activated.



ENTER KEY: allows validation of what has been typed.



PROTECTED RESET BUTTON: it is activated by inserting a blunt object in the slot while simultaneously pressing the trigger.

3.2 BARCODE SCANNING

When reading a barcode point the terminal laser beam at the code from an appropriate distance and simultaneously press the trigger. The beam emitted by the laser must completely cover the barcode; the LED (and the acoustic signal, if activated) will indicate if the scan was carried out correctly.

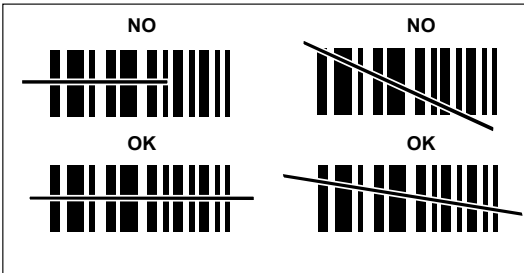



Figure 12 - F725-E Series Terminal Scanning a Barcode



NOTE

Throughout the operation of the application, the battery icon , and the time icon will always be activated, the latter in accordance with the setting of the terminal internal clock. In addition, when an acoustic signal is emitted, the loudspeaker icon  will appear.

3.3 DELETING THE APPLICATION PROGRAM

This procedure allows deleting application programs developed with DS for Formula™. If you want to delete programs provided or developed by EasyGen™, refer to chapter 6 of the EasyGen™ manual.



NOTE

The following procedure causes data to be deleted even if not completed.

If the application program must be cancelled follow the instructions below:

- 1- Press the trigger and the protected reset button at the same time; the display will show:

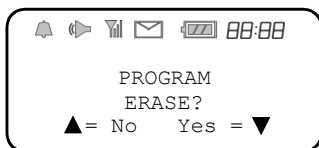

NOTE

If you do not want to delete the application program, press the {▲} or wait about 25 seconds.

- 2- To continue with the deletion, press the ▼ key; after a few seconds, the display will show:

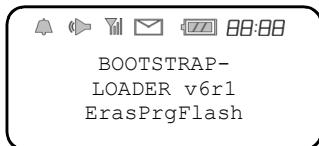

- 3- Once the deletion procedure is completed, the terminal is ready to receive a new application program. This is installed using the methods described in the DS for Formula™ manual.

3.4 DOWNLOADING DATA TO HOST

Data can be downloaded from the terminal to the host PC in different ways, depending on the application loaded and on the terminal model.

If working with F725-E (batch model), the application software allows downloading data onto the PC by simply inserting the terminal into the cradle or by direct operator intervention on the terminal or host computer.

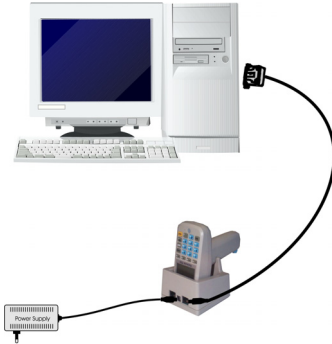

Figure 13 - Downloading Data with F725-E

If working with F725-E/RF, the application software will allow downloading data by radio frequency transmission between the terminal and a STARGATE™ RF base station.

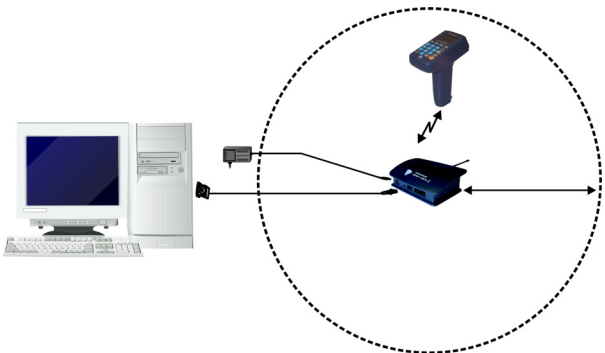

Figure 14 - Downloading Data with F725-E/RF

4 MAINTENANCE



NOTE

Rechargeable battery packs (NiCd/NiMh) are not initially charged. Therefore the first operation to perform is to charge them in the appropriate cradle. See chapter 2 and the following paragraph "Charging the Batteries".

4.1 CHARGING THE BATTERIES

Battery charge life depends on many variables but, under normal conditions, autonomy is more than enough for a day work.

Information on the battery-charge status is provided by the dedicated icon on the display . The information provided by the icon is valid only when the terminal is not inserted in the cradle.

Four different charge levels are given from a maximum value (all the icon segments full) to a minimum one which warns of pre-low-battery (icon empty and intermittently flashing).

Recharging should be made after using the terminal until the batteries are nearly flat.



CAUTION

When the terminal display window shows the message "BATTERY LOW", wait until it is turned off before inserting it in the cradle.

Recharge the terminal by simply inserting it into its cradle; Datalogic S.p.A. recommends a minimum uninterrupted recharging time of eight hours. When using the NiMh battery a standard recharge does not allow taking fully advantage of the improved battery technology. For this reason, a recharging time of about 60 hours is advised to get the NiMh maximum capacity.

When batteries are new, or have not been recharged for a long time, it is necessary to perform two or three charge and discharge cycles (with complete use) before the batteries are able to reach their maximum capacity.



NOTE

During the battery recharge the color of the LED positioned on the cradle changes from red to green. If using the NiCd battery pack, the LED color changes when 70-80% of the complete charge is reached. If using the NiMh battery pack, the LED color changes when 50-60% of the complete charge is reached due to the battery increased capacity.

**CAUTION**

If the terminal remains inactive for a prolonged period such as two weeks, it is advisable to download all the stored data onto a computer and extract the battery pack.

4.2 REPLACING THE BATTERIES

**CAUTION**

Before proceeding, ensure that the terminal is switched off and that the data it contains has been downloaded onto the host computer.

To replace the batteries correctly, proceed as follows.

- 1- Turn over the terminal, place it on a soft surface and unscrew the cover on the bottom of the handle by using a coin and turning in a counter-clockwise direction.



- 2- Insert the battery pack making sure that the polarity symbols match.



- 3- Close the battery again by fitting the cover as shown in the figure and screw shut by turning clockwise.



WARNING

Do not incinerate, disassemble, short terminals or expose to high temperature. Risk of fire, explosion. Use specified charger only. Risk of explosion if the battery is replaced by an incorrect type. Dispose of the batteries as required by the relevant laws in force.

4.3 CLEANING THE TERMINAL

Clean the terminal from time to time with a slightly damp cloth. Do not use alcohol, corrosive products or solvents.

5 TROUBLESHOOTING

PROBLEM	CAUSE	REMEDY
When the trigger is pressed the terminal does not come on.	Flat batteries.	Recharge terminal.
	Batteries completely flat or broken.	Replace batteries.
When the trigger is pressed, the terminal displays the message BATTERY LOW and switches itself off.	Flat batteries.	Recharge terminal.
	Batteries completely flat or broken.	Replace batteries.
The terminal does not load the application program.	There is no power supply to the cradle.	Connect the power supply and switch on the cradle.
	The serial cable is not correctly connected.	Check the connection to the cradle and the serial port of the computer.
	The terminal already contains an application program.	Follow instructions to cancel the application.
The terminal displays an error message FAULT CODE.P21CO4.	The application loaded is not suitable for the terminal in use. The terminal displays the message FAULT CODE P21CO4.	Load the correct application program.
	Other faults. The terminal displays an error message other than FAULT CODE P21CO4.	Contact your Datalogic representative for technical assistance.

6 TECHNICAL FEATURES

Optical Features	F725-E Std	F725-E LR
Light source	Laser-scanner; VLD source; 630-680 nm	
Scan rate	35±5 scans/sec	
Minimum resolution	0.15 mm / 6 mils	0.25 mm / 9.8 mils
Skew angle	± 65°	± 60°
Pitch angle	± 65 °	
Depth of field	30 to 700 mm / 1.2 to 27.6 in (depends on the code density)	20 to 180 cm / 7.8 to 70.8 in (depends on the code density)
Electrical Features	F725-E	F725-E/RF
Micro-controller	8-bit CMOS 8 KB bootstrap-loader PROM	
Program memory	512 KB Flash-memory	
Data RAM	512 KB or 2 MB RAM (only for batch models)	
EEPROM	256 bytes	
Calendar/clock	Quartz RT, programmable date and time with automatic handling of leap years.	
Power supply	4 NiCd 250mA/h batteries	4 NiMh 650 mA/h batteries
Battery charger	Formula 925 or Formula 925/4	
Physical Features	F725-E	F725-E/RF
Technology	SMT (Surface Mount Technology)	
Dimensions (LxWxH)	110 x 56 x 147 mm / 4.3 x 2.2 x 5.8 in	
Weight	240 g / 8.5 oz	255 g / 9.01 oz
Buzzer	Piezoelectric, programmable in frequency and duration	
LED	Programmable red/green LED	
Display	High contrast, back-lit LCD graphic display with 97 x 32 matrix	
Keyboard	20 silicone rubber keys, reset button	
Environmental Features		
Working temperature	0 °C to +50 °C (32 °F to +122 °F)	
Storage temperature	-20 °C to +70 °C (-4 °F to +158 °F)	
Relative humidity	95% without condensation	
Degree of protection	Protected from rain and dust	
Electrostatic charges	IEC 801-2	
Drop resistance	IEC 68-2-32 up to 1 m (39 in) onto concrete	
Laser safety	EN 60825-1 class 2 laser product	
Programming Features		
Bar codes decoded	Standard 3/9 Extended 3/9 Italian pharmaceutical Interleaved 2/5 ITF 14 Industrial 2/5 Matrix 2/5 UPC - EAN UPC only UPC/EAN + Addon 2 UPC/EAN + Addon 5 UPC-E only UPC 8 only UPC-A & EAN 13 only Codabar (NW7) Monarch (2/7) PAKO Code 128	

	EAN 128 Delta A IBM MSI Code 93 Zellweger Storagetek
Operating modes	Bootstrap loader; application program
Transmission Features	
F925 - F925/4 interface	via optical transceiver with serial protocol
Cradle-Host interface	RS232; RS485; Eavesdrop
Transmission speed	300 to 19200 bits/sec
Transmission protocol	Program-definable
Transmission modes	RS232 full-duplex; RS485 half-duplex
Parity	mark, space, odd, even
F725-E/RF Transmission Features	
Frequency	433.92 MHz
Power emitted	10 mW Max

GLOSSARY

Barcode

A pattern of variable-width bars and spaces which represents numeric or alphanumeric data in binary form. The general format of a barcode symbol consists of a leading margin, start character, data or message character, check character (if any), stop character, and trailing margin. Within this framework, each recognizable symbology uses its own unique format.

Baud Rate

A measure for data transmission speed.

Bit

Binary digit. One bit is the basic unit of binary information. Generally, eight consecutive bits compose one byte of data. The pattern of 0 and 1 values within the byte determines its meaning.

Bits per Second (bps)

Number of bits transmitted or received per second.

Byte

On an addressable boundary, eight adjacent binary digits (0 and 1) combined in a pattern to represent a specific character or numeric value. Bits are numbered from the right, 0 through 7, with bit 0 the low-order bit. One byte in memory can be used to store one ASCII character.

Decode

To recognize a barcode symbology (e.g., Codabar, Code 128, Code 3 of 9, UPC/EAN, etc.) and analyze the content of the barcode scanned.

EEPROM

Electrically Erasable Programmable Read-Only Memory. An on-board non-volatile memory chip. Data is maintained when power is not present.

FLASH

It is a type of non-volatile memory that can be erased and reprogrammed in units of memory called *blocks*. It is a variation of EEPROM memory which, unlike flash memory, is erased and rewritten at the byte level, and therefore is slower than flash memory updating. Data is maintained when power is not present.

Host

A computer that serves other terminals in a network, providing services such as network control, database access, special programs, supervisory programs, or programming languages.

Liquid Crystal Display (LCD)

A display that uses liquid crystal sealed between two glass plates. The crystals are excited by precise electrical charges, causing them to reflect light outside according to their bias. They use little electricity and react relatively quickly. They require external light to reflect their information to the user.

Light Emitting Diode

A low power electronic light source commonly used as an indicator light. It uses less power than an incandescent light bulb but more than a Liquid Crystal Display (LCD).

RAM

Random Access Memory. Data in RAM can be accessed in random order, and quickly written and read. This memory is volatile and therefore data is lost when power is not present.

RTC

Real Time Clock.

Terminal

A Datologic portable computer product.

INDEX

- A**
Accessories; 6
Application Development Programs; 4
- B**
Barcode Scanning; 19
- C**
Connections; 7
 Connection Cable; 14
 Connection with Eavesdrop
 Interface; 10
 Cradle; 7
 RF Connection; 13
 RS232 Connection; 8
 RS485 Connection; 11
- D**
Deleting the Application Program; 20
Downloading Data to Host; 21
Downloading EasyGen™ Demo; 5
- G**
General View; xiii
- M**
Maintenance; 22
 Charging the Batteries; 22
 Cleaning the Terminal; 25
 Replacing the Batteries; 24
- P**
Package Contents; 5
- R**
Reference Documentation; v
- S**
Safety Regulations; vi
 FCC Compliance; xii
 Laser Safety; vii
 Radio Compliance; xi
 WEEE Compliance; xii
- T**
Technical Features; 27
 Electrical; 27
 Environmental; 27
 Optical; 27
 Physical; 27
 Programming; 28
 RF Transmission; 28
 Transmission; 28
troubleshooting; 26
- U**
Use and Operation; 16

dichiara che
declares that the
déclare que le
bescheinigt, daß das Gerät
declare que el

F725-E/RF/512 K, Laser Terminal
F725-E/LR/RF/512K, Laser Terminal

e tutti i suoi modelli
and all its models
et tous ses modèles
und seine modelle
y todos sus modelos

sono conformi alla Direttiva del Consiglio Europeo sottoelencata:
are in conformity with the requirements of the European Council Directive listed below:
sont conformes aux spécifications de la Directive de l'Union Européenne ci-dessous:
der nachstehenden angeführten Direktive des Europäischen Rats entsprechen:
cumple con los requisitos de la Directiva del Consejo Europeo, según la lista siguiente:

1999/5/EEC R&TTE

Questa dichiarazione è basata sulla conformità dei prodotti alle norme seguenti:
This declaration is based upon compliance of the products to the following standards:
Cette déclaration repose sur la conformité des produits aux normes suivantes:
Diese Erklärung basiert darauf, daß das Produkt den folgenden Normen entspricht:
Esta declaración se basa en el cumplimiento de los productos con las siguientes normas:

ETSI EN 301 489-3 v1.4.1, AUGUST 2002:

ELECTROMAGNETIC COMPATIBILITY AND
RADIO SPECTRUM MATTERS (ERM);
ELECTROMAGNETIC COMPATIBILITY (EMC)
STANDARD FOR RADIO EQUIPMENT AND
SERVICES; PART 3: SPECIFIC CONDITIONS
FOR SHORT-RANGE DEVICES (SRD)
OPERATING ON FREQUENCIES BETWEEN 9
KHZ AND 40 GHZ

ETSI EN 300 220 v1.1.1, SEPTEMBER 2004:

ELECTROMAGNETIC COMPATIBILITY AND
RADIO SPECTRUM MATTERS (ERM);
SHORT-RANGE DEVICES (SRD); RADIO
EQUIPMENT TO BE USED IN THE 25MHZ TO
1000MHZ FREQUENCY RANGE WITH
POWER LEVELS RANGING UP TO 500MW;
PART 3: HARMONIZED EN COVERING
ESSENTIAL REQUIREMENTS UNDER ARTICLE
3.2 OF THE R&TTE DIRECTIVE

EN 60950-1, DECEMBER 2001:

INFORMATION TECHNOLOGY EQUIPMENT –
SAFETY – PART 1: GENERAL
REQUIREMENTS

Lippo di Calderara, March 8th, 2007

Paola Chientaroli
Quality Assurance Manager



www.mobile.datalogic.com

World wide Sales Network
available from: www.mobile.datalogic.com/contacts

Datalogic Mobile S.r.l.

Via S. Vitalino, 13
40012 Lippo di Calderara di Reno
Bologna - Italy
Telephone: (+39) 051-3147011
Fax: (+39) 051-3147561



822000052 (Rev. C)